

---

# **INSTALLATION AND USER MANUAL BUILT-IN GAS OVENS**

**EN**

## CONTENTS

<b>INTRODUCTION AND WARNINGS</b>	<b>4</b>
<b>MANUFACTURER LIABILITY</b>	<b>4</b>
<b>ENVIRONMENTAL PROTECTION</b>	<b>4</b>
<b>PLASTIC PACKAGING</b>	<b>4</b>
<b>APPLIANCE DATA PLATE</b>	<b>4</b>
<b>GENERAL SAFETY INSTRUCTIONS</b>	<b>5</b>
<b>USAGE INSTRUCTIONS</b>	<b>6</b>
<b>INSTALLATION INSTRUCTIONS</b>	<b>6</b>
<b>TECHNICAL INSTALLATION INSTRUCTIONS</b>	<b>6</b>
<b>INSTALLING THE OVEN IN THE UNIT</b>	<b>7</b>
<b>IMPORTANT INFORMATION</b>	<b>7</b>
<b>INSTALLING THE OVEN BELOW A HOB</b>	<b>8</b>
<b>INSTALLING THE OVEN IN A TALL APPLIANCE HOUSING</b>	<b>8</b>
<b>OVEN FASTENING</b>	<b>9</b>
<b>ELECTRICAL CONNECTION</b>	<b>9</b>
<b>MAINTENANCE</b>	<b>10</b>
<b>REPLACING COMPONENTS</b>	<b>10</b>
<b>GAS CONNECTION</b>	<b>11</b>
<b>GENERAL INFORMATION</b>	<b>11</b>
<b>CONNECTING THE APPLIANCE TO THE GAS SUPPLY</b>	<b>11</b>
<b>PRECAUTIONS WHEN USING THE PRODUCT WITH LPG (BUTANE/PROPANE)</b>	<b>12</b>
<b>AREA VENTILATION</b>	<b>12</b>
<b>EXTRACTION OF COMBUSTION PRODUCTS</b>	<b>12</b>
<b>GAS CONVERSION</b>	<b>13</b>
<b>GAS CONVERSION TABLE</b>	<b>14</b>
<b>USING THE APPLIANCE</b>	<b>15</b>
<b>CONTROL PANEL</b>	<b>15</b>
<b>THREE-KNOB OVEN CONTROLS</b>	<b>15</b>
<b>TWO-KNOB OVEN CONTROLS</b>	<b>15</b>
<b>OVEN FUNCTIONS</b>	<b>15</b>
<b>BEFORE FIRST USE</b>	<b>16</b>
<b>RACK POSITIONING</b>	<b>16</b>
<b>COOLING</b>	<b>16</b>
<b>PRE-HEATING</b>	<b>16</b>
<b>LIGHTING THE GAS OVEN</b>	<b>16</b>
<b>LIGHTING THE GAS GRILL (BROILER)</b>	<b>16</b>
<b>COOKING MODES</b>	<b>17</b>
<b>CONDENSATION</b>	<b>17</b>
<b>COOKING TIPS</b>	<b>18</b>
<b>SAVING ENERGY</b>	<b>18</b>
<b>COOKING GUIDELINES</b>	<b>19</b>
<b>COOKING INTERFACES</b>	<b>20</b>
<b>TOUCHSCREEN DISPLAY</b>	<b>20</b>
<b>TIMER</b>	<b>20</b>
<b>THERMOMETER</b>	<b>21</b>
<b>ACCESSORIES</b>	<b>22</b>
<b>TELESCOPIC RAILS</b>	<b>22</b>
<b>ROTISSERIE FUNCTION</b>	<b>22</b>
<b>CLEANING THE APPLIANCE</b>	<b>23</b>
<b>BASIC MAINTENANCE</b>	<b>24</b>
<b>REMOVING THE SIDE GUIDES</b>	<b>24</b>
<b>REPLACING THE OVEN LIGHT BULB</b>	<b>24</b>
<b>CLEANING THE INTERNAL DOOR GLASS</b>	<b>25</b>
<b>TROUBLESHOOTING</b>	<b>26</b>



## INTRODUCTION

READ THESE INSTRUCTIONS CAREFULLY BEFORE INSTALLING AND USING THE APPLIANCE.

These instructions are valid only for the countries whose identifying symbols are included on the cover of this manual and on the appliance label.

The manufacturer shall not be held liable for property damage or personal injury resulting from incorrect installation or improper use of the appliance.

The manufacturer shall also not be held liable for any imprecisions due to printing or transcription errors in this booklet.

The appearance of the figures included herein is only for guidance.

The manufacturer reserves the right to make modifications to its products when it considers this necessary or beneficial, however the essential safety and performance characteristics shall not be affected.

THIS APPLIANCE IS DESIGNED FOR NON-PROFESSIONAL, DOMESTIC USE.

This user manual is an integral part of the appliance and must therefore be kept in its entirety in a place accessible to the user for the entire lifetime of the appliance.

Read this manual before using the appliance.

### MANUFACTURER LIABILITY

The manufacturer shall bear no liability for property damage or personal injury due to:

- Use of the appliance other than that specified.
- Failure to comply with the instructions in the user manual.
- Tampering with/unauthorised modifications to any part of the appliance.
- The use of non-original spare parts.
- This appliance is intended for cooking food in the home environment. Any other use shall be considered improper.
- The appliance is not designed to operate with external timers or with remote-control systems.

**WARNING:** The  $\text{CE}$  marking on this product is a declaration, under the manufacturer's full responsibility, that the product complies with all European health, safety and environmental requirements laid out in the legislation covering this product type.

## ENVIRONMENTAL PROTECTION



Please think of the environment when disposing of the packaging.

This appliance is marked in accordance with European Community Directive 2012/19/EU on waste electrical and electronic equipment (WEEE).

This directive defines the standards for the collection and recycling of waste electrical and electronic equipment applicable throughout the European Union.

The packaging of this appliance is composed of the elements strictly necessary to ensure sufficient protection during transport. The packaging materials are completely recyclable, thus reducing their environmental impact. Please help to protect the environment by taking the following tips into consideration:

- Sort the packaging materials for recycling.
- Render the old appliance unusable before taking it to the collection facility. Ask the competent local authorities for details of the nearest recycling centre you can take the old appliance to.
- Do not dispose of used oil down the drain. Keep it in a closed container and take it to a recycling centre; if this is not possible, dispose of it in mixed waste (in this manner it will be disposed of at a monitored facility – although this is not the best solution, it at least prevents contamination of the sewage/water systems).

### PLASTIC PACKAGING

Danger of suffocation

- Do not leave the packaging or any part thereof unattended.
- Do not let children play with the plastic bags.

### APPLIANCE DATA PLATE

The data plate bears the technical data, serial number and brand name of the appliance. The appliance data plate is located on the side of the front of the oven, and must not be removed at any time. A copy is provided in this manual for reference.

## INTRODUCTION

### GENERAL SAFETY INSTRUCTIONS

- During use, the appliance and its accessible parts become very hot.
- Never touch the heating elements during use.
- Keep children under the age of eight at a safe distance unless they are constantly supervised.
- Children must not play with the appliance.
- This appliance may only be used by children over the age of eight, and by people with reduced physical, sensory or mental capacity, or lacking in experience in the use of electrical appliances, provided that they are supervised or instructed by adults who are responsible for their safety.
- Switch off the appliance after use.
- Cleaning and maintenance must not be carried out by children without adequate supervision.
- Ensure that hot surfaces are allowed to cool before proceeding to clean the appliance.
- Have installation and servicing carried out by qualified personnel in compliance with applicable standards and legislation. Do not try to repair the appliance yourself or without the assistance of a qualified technician.
- Gas appliances must only be connected up and worked on by qualified gas engineers, who must be licensed and registered in most jurisdictions.
- Pipes and hoses must not come into contact with moving parts and must not be crushed or pinched.
- Where required, use a pressure regulator meeting the appropriate standards and regulations.
- On completing installation, check for any leaks with a soapy solution, never with a flame.
- Do not modify this appliance.
- Do not insert anything in the slots.
- Do not obstruct ventilation openings and heat dispersal slots.
- If the power supply cable is damaged, contact technical support immediately and they will arrange for it to be replaced.
- Do not use abrasive or corrosive detergents (e.g. scouring powders, stain removers and metallic sponges) on glass parts.
- Do not sit or put any weight on the oven door.
- Do not use steam jets to clean the appliance.
- Do not use the appliance as a space heater for any reason.
- In the event of breakage or cracking in the glass, shut off the oven immediately and disconnect it from the power supply. Contact technical support.
- Sudden and extreme changes in temperature can cause the glass to break – never pour cold liquids onto the oven door.
- Using the oven generates heat and moisture – keep the area well ventilated during operation.
- Never place flammable objects in the oven
- Do not open the door if smoke is coming out of the oven. Shut the appliance off, isolate its electrical connection and disconnect the gas supply.
- The oven contains electronic components which could interact with electronic medical equipment such as pacemakers or insulin pumps. Equipment of this type must be kept at least 10 cm from the oven.
- Ensure that there are no trapped objects which could prevent the oven door from shutting.
- The oven is not designed to operate with timers or remote control systems.
- Plastic containers not designed for high temperatures could melt, damaging the oven or even catching fire.
- Closed tins and jars could burst or even explode if heated: never use the oven for preparing or heating tins or jars.
- Keep the door seal clean to prevent heat escaping and damaging adjacent units.
- Insert oven racks and trays all the way into their guides to prevent damage to the door when closing.

## INTRODUCTION

### INSTRUCTIONS FOR USE

- Take great care when cooking food with a high alcohol content, as this could cause a fire.
- Remove any food residue from inside the oven before using the appliance in order to prevent fires and smoking.
- Do not place any objects or baking paper on the bottom of the oven.
- After cooking, keep the door closed while the oven is cooling down to prevent damaging adjacent kitchen units.
- Fruit juice can cause indelible staining; use deep dishes to prevent leakage.
- Damaged containers, or those which are unsuitably small, can lead to serious injuries.
- When opening the oven door, be very careful of escaping steam: burn hazard!
- Do not pour water into a hot oven: this would create steam, and thus a burn hazard!
- Keep the door seal clean to prevent heat escaping and damaging adjacent units.
- Insert oven racks and trays all the way into their guides to prevent damage to the door when closing.

### INSTALLATION INSTRUCTIONS

#### THIS APPLIANCE MUST NOT BE INSTALLED IN BOATS OR CARAVANS

The appliance must not be installed on a pedestal.

- Position the appliance into the carcass with the help of a second person.
- To prevent overheating, the appliance must not be installed behind a decorative door or panel.
- Gas appliances must only be connected up and worked on by qualified gas engineers, who must be licensed and registered in most jurisdictions.
- When connecting up the gas hose, this must not exceed the maximum length provided for by regulations.
- Pipes and hoses must not come into contact with moving parts and must not be crushed or pinched.
- Where required, use a pressure regulator meeting the appropriate standards and regulations.
- Check the tightness of the gas connections after all work.

- On completing installation, check for any leaks with a soapy solution, never with a flame.
- Have installation and servicing carried out by qualified personnel in compliance with applicable standards and legislation.
- The electrical connection must be made by a qualified electrician.
- Earthing is mandatory, in accordance with local electrical codes.
- Use flex rated to support temperatures of at least 90 °C.
- If the power supply cable is damaged, contact technical support immediately and they will arrange for it to be replaced.
- Always wear the appropriate PPE when performing any work on the appliance (installation, maintenance, positioning or moving it).
- Shut off the main gas supply and isolate the relevant electrical circuit before carrying out any work.

## TECHNICAL INSTALLATION INSTRUCTIONS

The installation, adjustments, transformations and maintenance listed in this section must only be performed by qualified technicians (in accordance with applicable legislation). Incorrect installation can cause property damage and injury to people or pets; the manufacturer shall not be held liable in this event. The appliance's automatic regulation or safety devices may only be modified by the manufacturer or a duly authorised supplier during the appliance's lifetime.

**Ensure all necessary PPE is used when carrying out the installation**

### INSTALLING THE OVEN IN THE UNIT

Ensure that the oven is fully present and undamaged after removing all loose parts from their inner and outer packaging. In the event of any uncertainty, do not use the appliance and contact technical support.

Check that the kitchen unit is suitable for installation of the oven, referring to the dimensions given in this guide.

### IMPORTANT INFORMATION

The oven is only suitable for installation inside a fitted kitchen unit or carcass. The sides and surrounding surfaces must be able to withstand temperatures of up to 90°C.

Installation of the appliance must be performed in accordance with the provisions of applicable legislation.

An opening must be present in the rear of the carcass to allow for oven ventilation, as shown in the figure.

Use the supplied brackets to attach to the carcass (two brackets per side, see figure below).

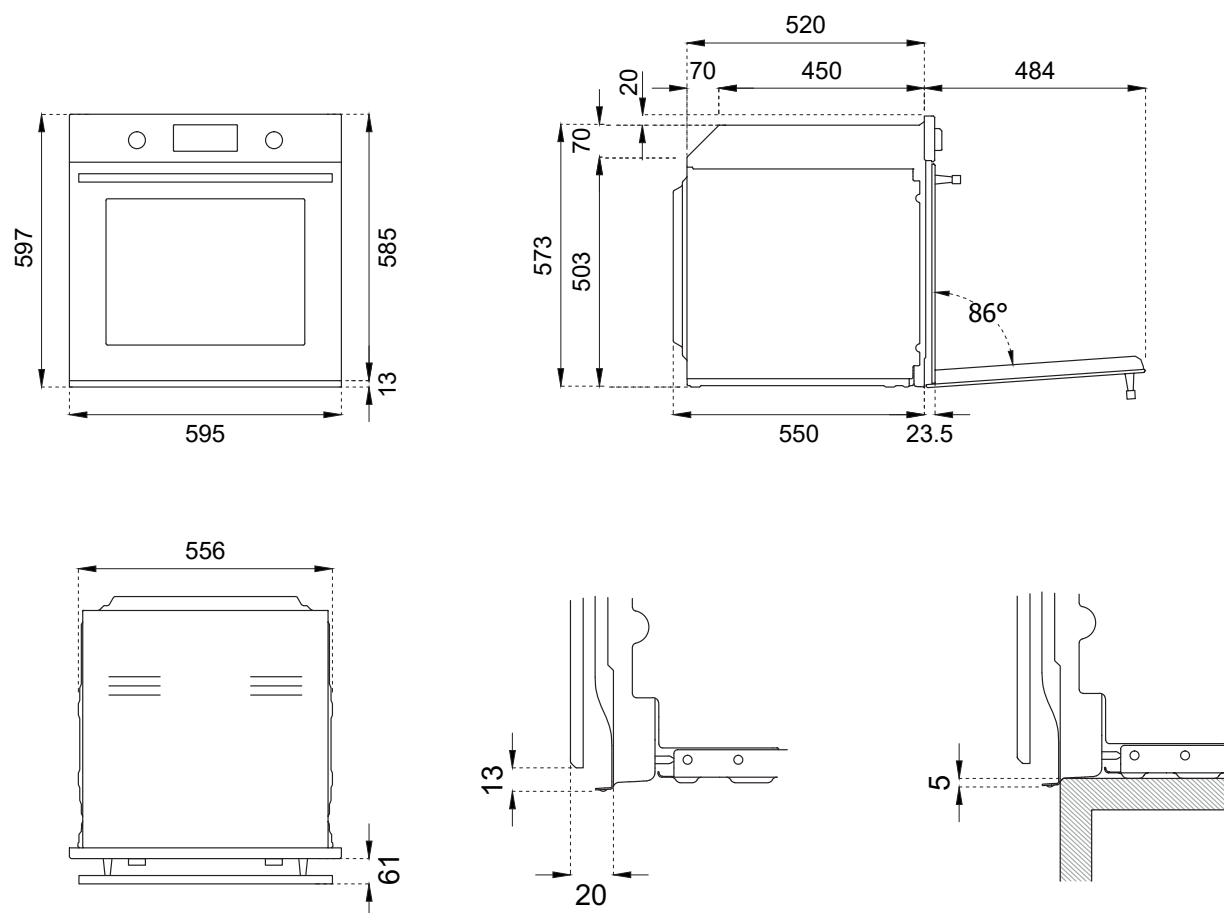
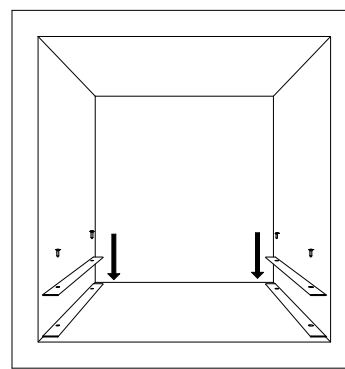

EN

## TECHNICAL INSTALLATION INSTRUCTIONS

### INSTALLATION UNDERNEATH A BUILT-IN HOB

The clearance between the oven and the kitchen units or other installed appliances must be enough to ensure sufficient ventilation and air discharge. If installed under a hob, space must be left between the bottom of the hob and the top of the oven to allow for ventilation of the entire compartment (see figure).

Any ventilation openings required for the hob are to be added to those required by the oven.

The manufacturer shall bear no liability in the event of the oven being installed in combination with a hob from another manufacturer.

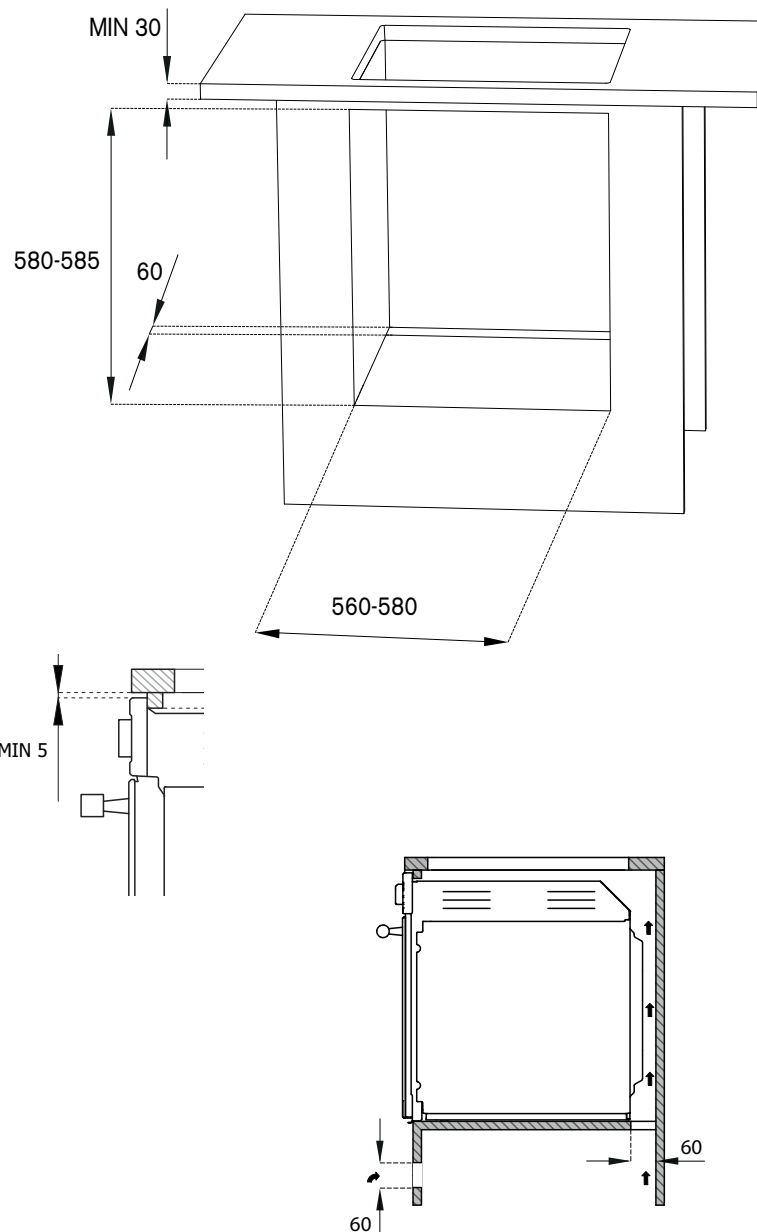

### INSTALLING THE OVEN IN A TALL APPLIANCE HOUSING

The clearance between the oven and the kitchen units must be enough to ensure sufficient ventilation and air discharge. Ensure there is an opening in the top or rear of the carcass as shown in the figure.

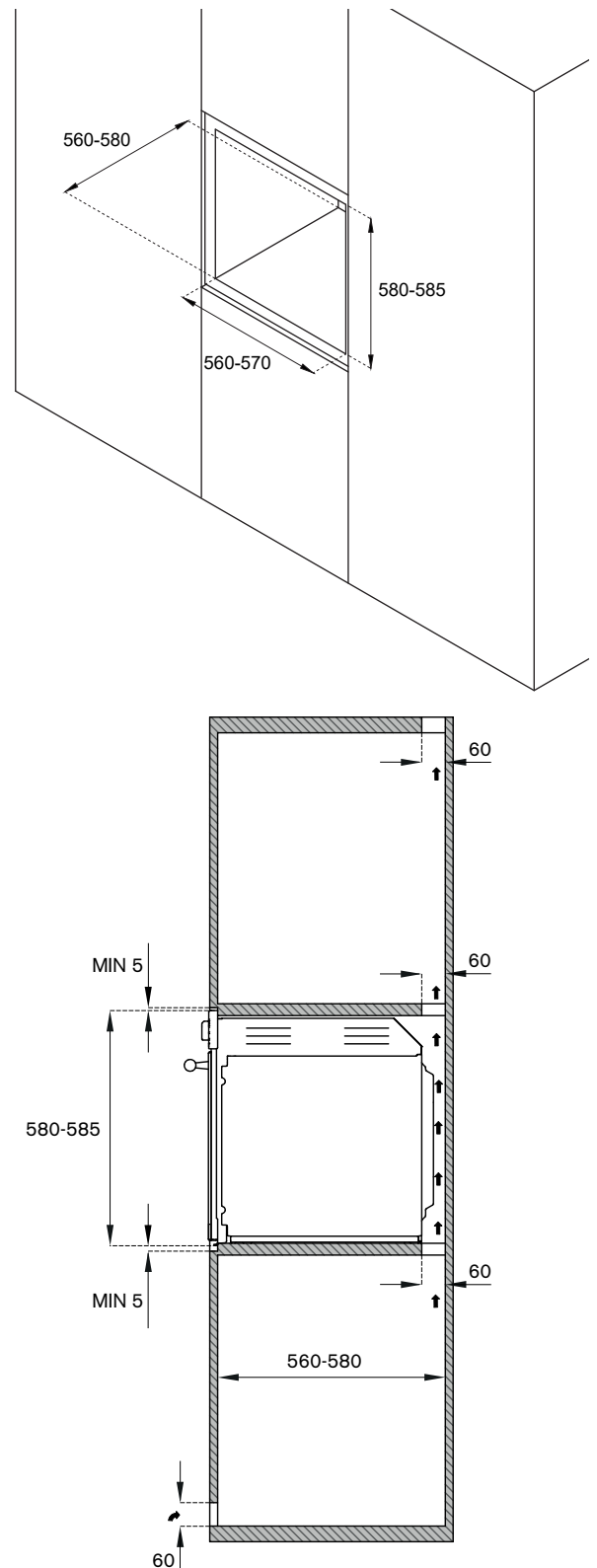



## OVEN FASTENING

- Position the appliance into the carcass with the help of a second person.
- Do not use the door or handle to position the oven.
- Check that the oven is correctly aligned with the units.
- Check that the door opens correctly.
- Fasten the oven to the carcass with the supplied screws, ensuring that the oven remains centred.
- Cover the screws with the caps.

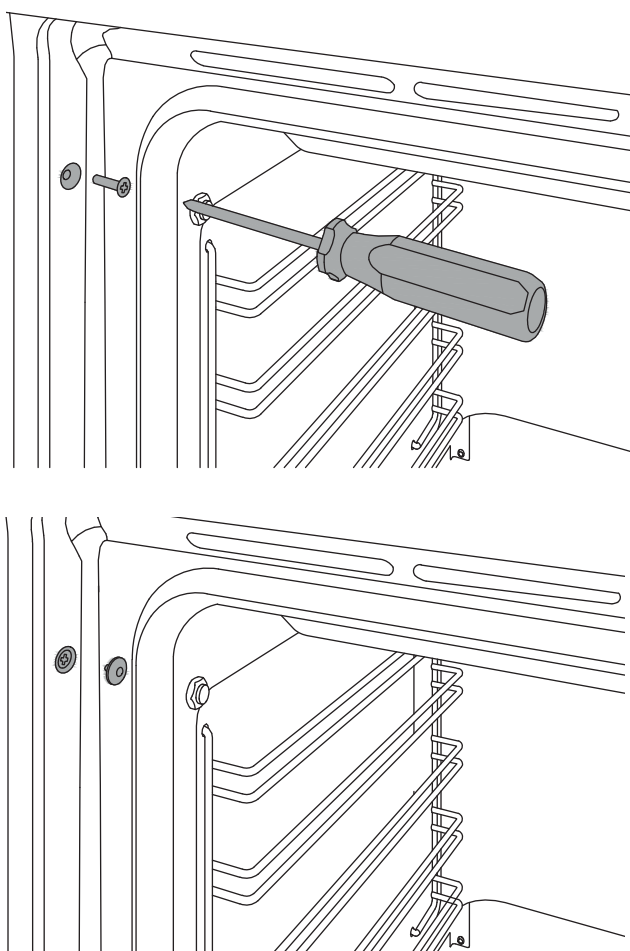

## ELECTRICAL CONNECTION

The electrical connection must be made in accordance with applicable standards and legislation.

Before connecting up the appliance, check that:

- The mains electricity supply matches the characteristics indicated on the appliance data plate.
- The circuit wiring and outlet are equipped with a compliant earth connection.

When the oven is connected to the mains power supply via a socket:

- Wire a plug onto the power cable which must comply with applicable standards in the country of use; the plug (and its fuse, where applicable) must be suitable for the rated load specified on the appliance data plate. Connect the cores of the cable in accordance with the figure, ensuring you follow the harmonised wiring colour scheme:

L (live/hot/phase) = brown wire

N (neutral) = blue wire

earth “ $\perp$ ” symbol = yellow/green wire

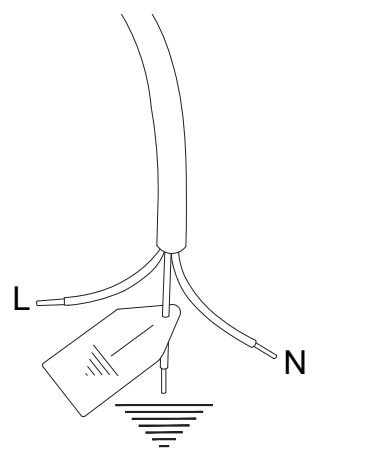

<b>Oven type</b>	<b>Five-function</b>
<b>Voltage</b>	220-240 V
<b>Frequency</b>	50/60 Hz
<b>Max. power</b>	90 W
<b>Max current draw</b>	1 A
<b>Cable type</b>	3x0.75 mm <sup>2</sup>

EN

- The power supply cable must be positioned in such a way that it is not resting against the rear of the oven, that it is not in contact with sharp edges and will not reach a temperature of 90°C at any point.
- Do not use adapters, extension leads, gang sockets etc. as these could cause loose contacts and overheat.

EN When the appliance is to be hard-wired to the mains circuit:

- The circuit must be fitted with a omnipolar circuit breaker of suitable capacity for the appliance's rated load.
- The earth conductor must not be switched by the breaker and must be connected to the earthing system.
- As an alternative, an RCBO may also be used, or RCD protection in addition to or instead of a fuse or MCB, depending on the applicable electrical code.

## MAINTENANCE

### REPLACING COMPONENTS

Isolate the appliance's gas and electricity supplies before performing any maintenance.

Contact an authorised service centre if functional components require replacement.

**WARNING: If the power cable requires replacement, the installer/maintenance technician must use H05VV-F cable and leave the earth conductor around 2 cm longer than the live and neutral wires. They must also comply with the instructions given for the initial electrical connection.**

## GAS CONNECTION

- All gas connections must be made by a qualified, registered gas engineer.
- Before proceeding with the installation, check that the local supply (gas pressure and type) is compatible with the default appliance values.
- Take the necessary steps to ensure correct air circulation.
- Information on the gas supply can be found on the appliance data plate.
- This appliance is not connected to a combustion residue extraction device. Ensure that the appliance is connected in accordance with applicable installation regulations. Pay attention to ventilation requirements.
- After all work, check that the tightening torque of the gas connections is between 15 Nm and 20 Nm.
- Where required, use a pressure regulator meeting the appropriate standards and regulations.
- On completing installation, check for any leaks with a soapy solution, never with a flame.
- When connecting up the gas hose, this must not exceed the maximum length provided for by regulations.
- Pipes and hoses must not come into contact with moving parts and must not be crushed or pinched.

## GENERAL INFORMATION

Connection to the mains gas supply can be made using rigid copper tube, continuous wall or flexible steel hose, depending on the requirements of applicable local gas regulations.

The appliance is tested in accordance with the information given on the data plate. For use with other types of gas, see the "GAS CONVERSION" chapter. The incoming gas connection is externally threaded 1/2" BSPP (ISO 228-1).

## CONNECTING THE APPLIANCE TO THE GAS SUPPLY

Before connecting the appliance to the gas supply, check that the data on the product identification label is compatible with the gas supply specifications.

When the gas is supplied from the mains, the appliance must be connected to the gas supply with rigid copper tube or via a steel hose, in accordance with applicable legislation.

When the gas is supplied from a cylinder, via a compliant pressure regulator with continuous-wall stainless-steel hose, it is advisable to install a special after-market adapter on the hose to facilitate connection with the hose barb of the pressure regulator installed on the cylinder.

Do not tilt or overturn the cylinder.

Use high quality LPG; if you have any doubts, use an LPG filter.

The hose must not pass through compartments which may be filled, and must not come into contact with moving components such as drawers. On completing installation, check for any leaks with a soapy solution, never with a flame.

**WARNING:** Remember that the appliance's gas inlet is a male 1/2" BSPP fitting to ISO 228-1.

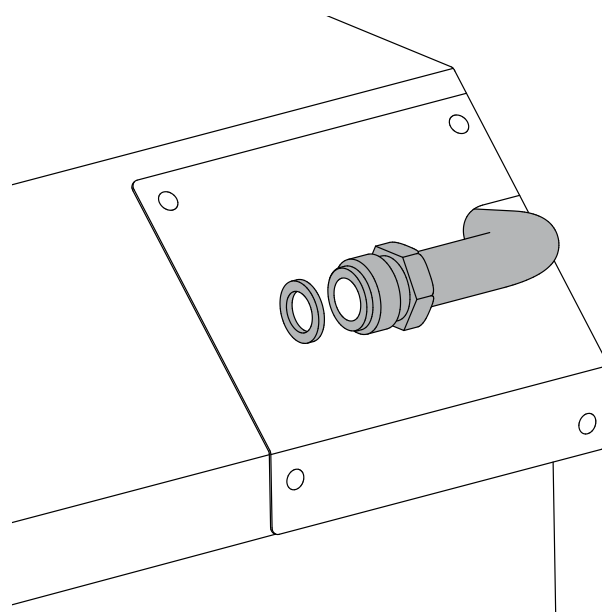

EN

## PRECAUTIONS WHEN USING THE PRODUCT WITH LPG (BUTANE/PROPANE)

The gas taps installed on the oven must operate with liquefied gas of controlled quality, supplied at the correct nominal pressure.

This pressure must be guaranteed by a certified dedicated pressure regulator (not supplied with the product).

EN

The use of gas from uncertified refills and/or improper use of LPG cylinders, as well as the corresponding regulator, can invalidate the product warranty.

In particular, you must avoid all situations where the gas could be polluted with residues and impurities which, when they enter the gas circuit, could irreparably damage the control components (thermostats).

We therefore recommend:

- Using only LPG cylinders from official resellers authorised by the various manufacturers
- Using the cylinders until they are empty but without tilting or overturning them
- Regularly cleaning the filter at the inlet to the pressure regulator

## ROOM VENTILATION

The appliance must only be installed in permanently ventilated locations, as provided for by applicable regulations. The location where the appliance is installed requires sufficient air flow to support both the combustion of the gas used and the necessary air exchange in the room itself. The air intakes, covered by protective grilles: in particular, after prolonged use, it is advisable to open a window or to increase the speed of any fans.

## EXTRACTION OF COMBUSTION PRODUCTS

The extraction of combustion products can be ensured via a hood connected to a flue with sufficient natural draw, or else by forced extraction. An efficient extraction system requires careful design by a qualified specialist, in compliance with the positioning and distances specified by regulations. Once the work is complete, the installer must issue a certificate.

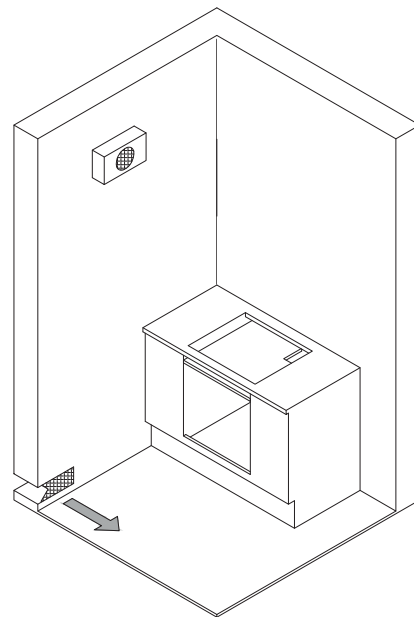
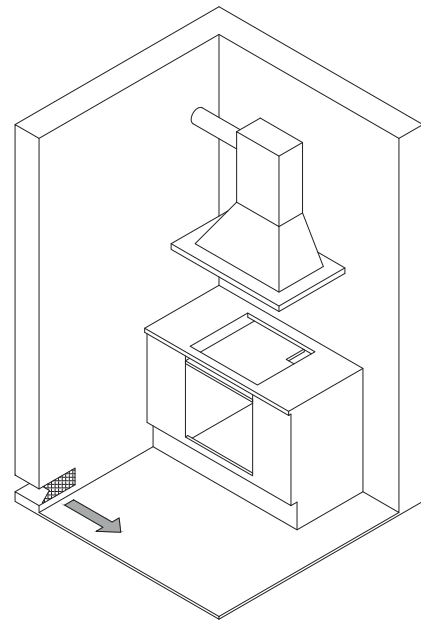

## GAS CONVERSION

### WARNING!

Isolate the appliance's gas and electricity supplies before performing any maintenance.

The gas conversion procedure involves two steps:

- Replacing the nozzles
- Burner minimum adjustment

**WARNING:** After performing the above-mentioned procedures, the technician must apply the label corresponding to the new gas regulation to replace the old one. This label is contained in the bag of spare nozzles.

### Step 1: Replacing the nozzles

Proceed as follows to replace the oven burner nozzle:

1. Open the oven door.
2. Remove any accessories from inside the oven.
3. Unscrew the fastening screws of the oven base and remove.
4. Slacken off screws A and B.
5. Remove the burner towards the outside in order to access the nozzle.
6. Change the nozzle using a 7mm box spanner.
7. Refit the burner and the oven base.

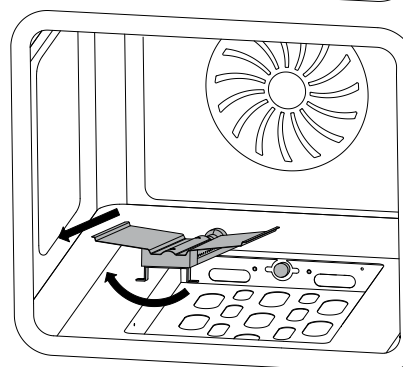
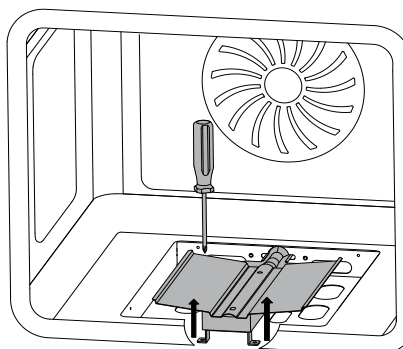
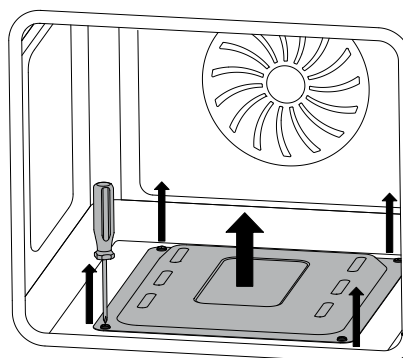

Proceed as follows to replace the grill (broiler) burner nozzle:

1. Open the oven door.
2. Remove any accessories from inside the oven.
3. Slacken off screw A.
4. Remove the grill burner towards the outside in order to access the nozzle.
5. Change the nozzle using a 7mm box spanner.
6. Refit the grill burner.

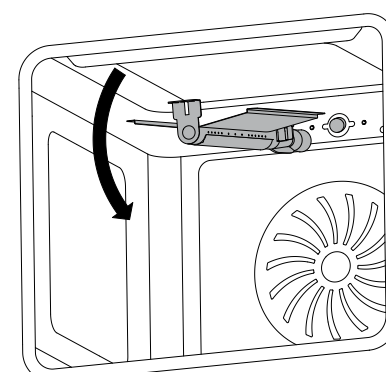
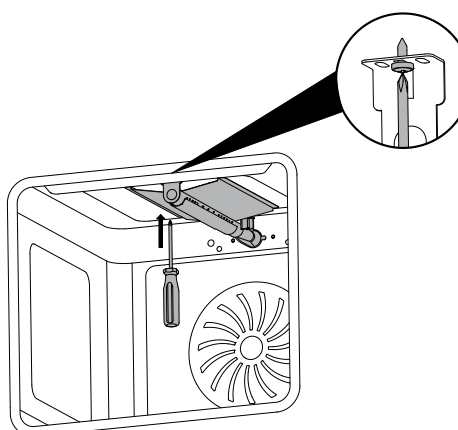

## GAS CONVERSION

### Step 2: Burner minimum adjustment

The oven thermostat has a screw for adjustment of the minimum burn position. When the gas supply type is changed, regulation of the minimum position is required as follows:

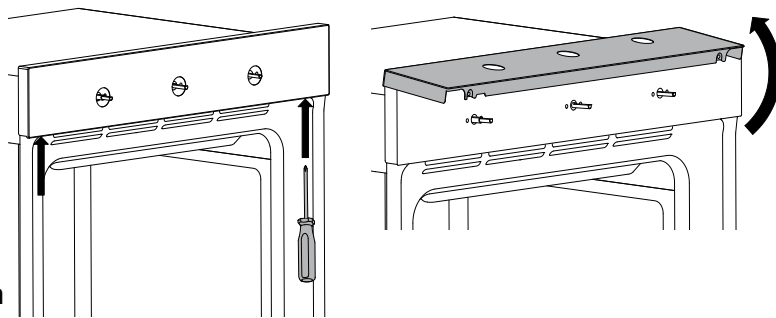

1. Pull the oven out from its niche by at least 5 cm (only ovens with metal control panel).
2. Slacken off the screws holding the control panel and remove it (only ovens with metal control panel).
3. Light the oven burner and run at maximum temperature for 10-15 minutes with the door closed.
4. Turn the knob to the minimum temperature position.
5. Remove the knob, introduce a flat-head screwdriver and turn the screw to adjust the minimum position.
6. When using liquefied gas, the screw will need to be turned all the way to the right.

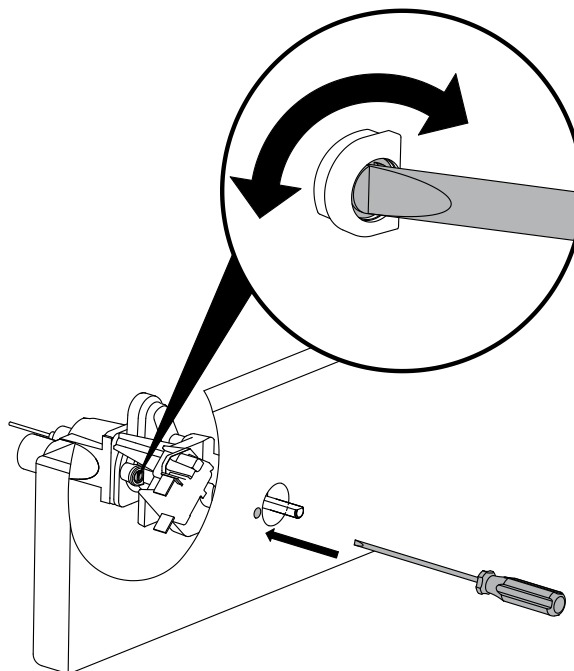

### GAS CONVERSION TABLE

Burner	Gas type	Pressure	N o z z l e diameter	Nominal flow rate				Flow rate Reduced		B y p a s s diameter
				g/h	l/h	kW	kcal/h	kW	kcal/h	
		mbar	1/100 mm	g/h	l/h	kW	kcal/h	kW	kcal/h	1/100 mm
Oven	Town gas G110	8	220	-	567	2.5	2150	0.8	688	41 reg
	Natural gas G20	20	113	-	238	2.5	2150	0.8	688	41 reg
	Butane G30	30	75	181	-	2.5	2150	0.8	688	41
	Propane G31	37	75	178	-	2.5	2150	0.8	688	41
Grill	Town gas G110	8	185	-	408	1.8	1548	-	-	-
	Natural gas G20	20	98	-	171	1.8	1548	-	-	-
	Butane G30	30	64	130	-	1.8	1548	-	-	-
	Propane G31	37	64	128	-	1.8	1548	-	-	-

## CONTROL PANEL

### THREE-KNOB OVEN CONTROLS

- 1 Temperature selector
- 2 Timer
- 3 Function selector

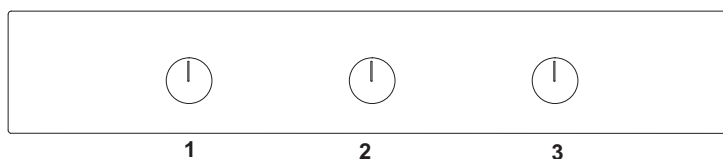

### TWO-KNOB OVEN CONTROLS

- 1 Temperature selector
- 2 Thermometer
- 3 Function selector

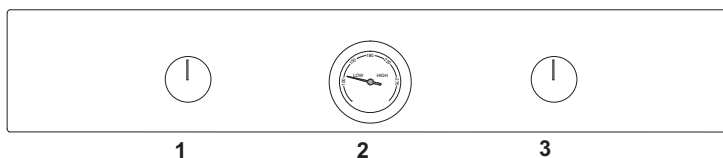



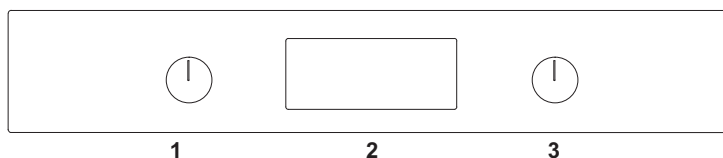

### TWO-KNOB OVEN CONTROLS

- 1 Temperature selector
- 2 Touchscreen displays
- 3 Function selector



## OVEN FUNCTIONS

SYMBOL	DESCRIPTION
	Grill
	Rotisserie
	Fan
	Light

EN

## USE

### BEFORE FIRST USE

- Remove any film and other packaging residue from the inside and outside of the oven.
- Remove and wash all accessories.
- Run the oven for 30 min. at 250°C without placing any food inside (during this operation it is normal for manufacturing residue to produce some smoke and odours).
- Let the oven cool down.
- Open the door and air the oven out for 15 minutes.
- Clean the inside of the oven.

### RACK POSITIONING

Racks and trays must be inserted into the side guides until they come to a complete stop to prevent contact with the oven door.

When removing accessories beyond halfway they are blocked to facilitate removing dishes.

The oven has five cooking levels indicated on the right-hand side of the front of the oven.

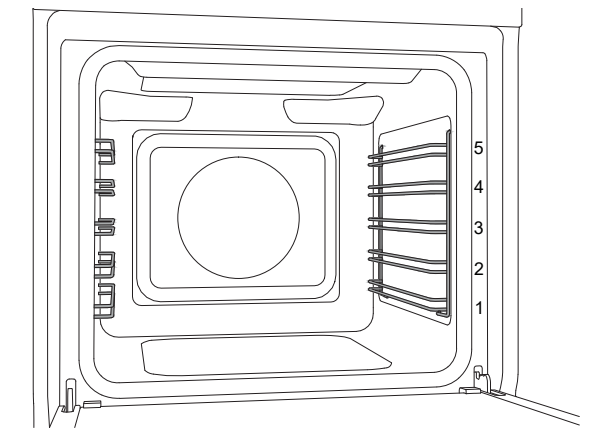

### COOLING

The oven is equipped with a cooling system which operates during cooking.

Air flow between the control panel and door allows the controls to be kept at a usable temperature.

The cooling system turns on and off automatically (it is normal for this to continue running after the oven is switched off).

### PRE-HEATING

Most recipes will require the dish to be placed in the oven when it has already reached the specified cooking temperature.

The pre-heating time will depend on the temperature set and the number of accessories present in the oven.

### LIGHTING THE GAS OVEN

Fully open the oven door.

Turn the thermostat knob anticlockwise to the max position (ignition).

Press and hold down the knob for at least 5 seconds. The electric spark ignition will operate automatically.

Release the knob and wait 15-20 seconds for the flame to stabilise, then close the oven door again.

Turn the knob to the chosen temperature.

*Oven lighting is disabled with the door open.*

If the burner does not light after 15 seconds, suspend your attempt to light the oven and leave the door open for at least one minute before attempting ignition again.

If the oven goes out accidentally, turn the thermostat knob to the off position, open the door and wait at least one minute before relighting the oven.

### LIGHTING THE GAS GRILL (BROILER)

Fully open the oven door.

Turn the thermostat knob clockwise to the GRILL position.

Press and hold down the knob for at least 5 seconds. The electric spark ignition will operate automatically.

Release the knob and wait 15-20 seconds for the flame to stabilise, then close the oven door again.

*Grill lighting is disabled with the door open.*

If the burner does not light after 15 seconds, suspend your attempt to light the oven and leave the door open for at least one minute before attempting ignition again.

If the oven goes out accidentally, turn the thermostat knob to the off position, open the door and wait at least one minute before relighting the oven.



## COOKING MODES

1. Insert the rack at the required level
2. Light the oven or grill burner and set the temperature (oven burner only).
3. Select the fan or rotisserie with the function knob, where required.

The oven is equipped with two burners, which can only be lit individually.

**Warning: all cooking operations must take place with the door closed.**

### Static cooking

*Heat from below.*

Cooking on a single level: ideal for roasts, bread and cakes.

At high temperatures, use this function for baked goods which you do not wish to brown.

- Roasts: level 2 or 3.
- Cakes: level 2 or 3.

### Grill

*Heat from the upper grill (fixed temperature)*

Cooking on a single level, ideal for grilling sausages, chops, bacon, fish or toast.

The grill must not be used for more than 30 minutes at a time.

Browning or gratinating food at the end of cooking.

- Level 4 or 5.

### Fan-assisted cooking

*Heat from below, with fan assist.*

Cooking on multiple levels, ideal for biscuits and cakes, or any type of food which requires even heat.

- Level 2 or 3 for cooking single items.
- Levels 2 and 4 for cooking multiple items.

Select the required temperature and the FAN function.

### Static with rotisserie

*Heat from below and rotisserie*

The rotisserie turns the food while the gas burner is lit, ideal for uniform cooking of large pieces of meat.

- Level 3 with skewer and skewer holder

Select the required temperature and the ROTISSERIE function.

### Grill with rotisserie

*Heat from the upper grill (fixed temperature) and rotisserie*

The rotisserie turns the food while the gas grill is lit.

The grill must not be used for more than 30 minutes at a time.

- Level 3 with skewer and skewer holder

Select the grill and the ROTISSERIE function.

### Defrost

This function speeds up defrosting through forced air circulation.

Select the LIGHT + FAN function, leaving the oven off.

### Oven Light

Select the LIGHT function.

### Proofing

This function maintains the heat necessary for proving dough. When using this function, it is advisable to insert the food with the oven cold.

Select the LIGHT function, leaving the oven off. Do not open the oven unless strictly necessary.

### N.B.:

In fan-assisted function and with the rotisserie, the light will also turn on.

### N.B.:

With the grill burner lit, the fan function will not operate.

### CONDENSATION

When cooking foods with a high water content, it is normal for condensation to form on the inside of the oven door and on the control panel. This condensation will evaporate by itself during cooking.

## COOKING TIPS

- The set temperature and cooking time may vary slightly from one oven to another. Slight adjustments to recipes may be necessary.
- Increasing the temperature does not decrease cooking times.
- Cooking times depend on the weight, thickness and quality of the food.
- We recommend placing the food at the centre of the rack.
- Choose the level in accordance with the recipe and personal experience.
- Leave at least 3 cm between oven dishes and the sides of the oven to allow heat to circulate.
- Use light-coloured aluminium trays when cooking pastries.
- Use dark metal tins for cooking sweets and biscuits, as they help absorb heat.
- Turn and mix dishes so that they heat through evenly.
- For new recipes, choose the lowest temperature from those given along with the shortest time; then assess how well cooked the dish is, prolonging the cooking if necessary.

## SAVING ENERGY

- Open the oven door only when necessary to avoid wasting heat.
- Keep the inside of the oven clean.
- Remove any accessories not currently being used.
- Shut off the oven a few minutes before the time normally used, allowing the residual heat of the oven to finish cooking.

## COOKING GUIDELINES

The times given in the table do not include preheating times and are provided only as a guide.

Food	Weight (kg)	Function	Temperature (°C)	Time (minutes)	
Lasagne	3-4	Static	220-230	45-50	
Baked pasta	3-4	Static	220-230	45-50	
Roast veal	2	Fan	180-190	90-100	
Pork loin	2	Fan	180-190	70-80	
Sausages	1.5	grill	175	15	
Roast beef	1	Fan	200	40-45	
Roast rabbit	1.5	Fan	180-190	70-80	
Turkey breast	3	Fan	180-190	110-120	
Roast pork neck	2-3	Fan	180-190	170-180	
Roast chicken	1.2	Fan	180-190	65-70	
				1st side	2nd side
Pork chops	1.5	grill	175	15	5
Spare ribs	1.5	grill	175	10	10
Bacon	0.7	grill	200	7	8
Pork fillet	1.5	grill	175	10	5
Beef fillet	1	grill	200	10	7
Rainbow trout	1.2	Fan	150-160	35-40	
Monkfish	1.5	Fan	160	60-65	
Turbot	1.5	Fan	160	45-50	
Pizza	1	Fan	MAX	8-9	
Bread	1	Fan	190-200	25-30	
Focaccia	1	Fan	180-190	20-25	
Bundt cake	1	Fan	160	55-60	
Jam tart	1	Fan	160	35-40	
Ricotta cake	1	Fan	160-170	55-60	
Stuffed tortellini	1	Fan	160	20-25	
Sponge cake	1.2	Fan	160	55-60	
Profiteroles	1.2	Fan	180	80-90	
Victoria sponge	1	Fan	150-160	55-60	
Rice cake	1	Fan	160	55-60	
Pastries	0.6	Fan	160	30-35	

## COOKING INTERFACES

### TOUCHSCREEN DISPLAY (where applicable)

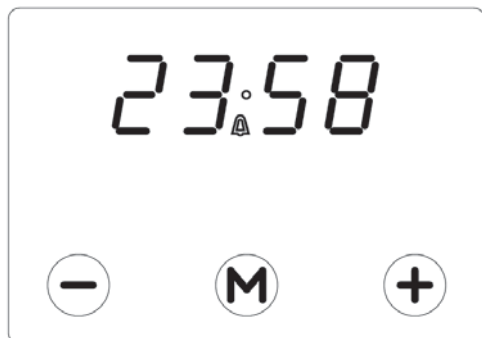

#### Setting the time

When the oven is first switched on, or after a power cut, the display will flash.

- To set the current time, press and hold the “M” button for at least 2 seconds. The display will stop flashing.
- Press the + or - button to correct the displayed time. A short period after releasing the button, the set information will be accepted.

#### Timer

This function consists simply of a countdown timer which can be set to a maximum time of 23 hours and 59 minutes, at the end of which a buzzer will sound; press any button to stop the buzzer.

- Press and hold the “M” button for at least 2 seconds, or in any case until the 🔔 symbol starts flashing.
- Set the time using the + or - button.
- After a few seconds, the current time will be displayed along with the symbol. The countdown timer will start immediately.
- After the set cooking time has finished, a buzzer will sound.

This function does not stop cooking; rather, it only sounds a warning buzzer when the time runs out. The user is responsible for manually stopping cooking with the corresponding knobs.

#### Disabling the Buzzer

To manually stop the buzzer, press any button.

#### Changing the Current Time and Adjusting the Buzzer Volume

To change the time

- press and hold the + and - buttons simultaneously for at least two seconds or in any case until the . dot flashes.
- Press the + or - button to change the time.

Adjusting the buzzer volume

- Press the M button. The following text will be shown on the display: “ton ...” followed by a number
- Select the required volume using the + or - button.

A power cut will cause the programmed settings, including the clock, to be lost. Once the power is back on, the clock must be reprogrammed.

### TIMER (where applicable)

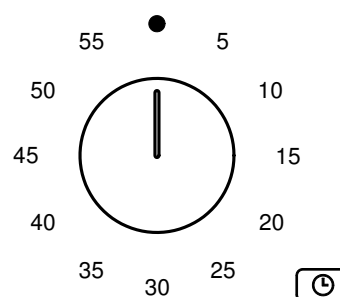

This function consists simply of a countdown timer which can be set to a maximum time of 60 minutes, at the end of which a buzzer will sound. Turn the timer knob clockwise all the way to wind the ringer.

Turn the knob anticlockwise to the chosen time.

This function does not stop cooking; rather, it only sounds a warning buzzer when the time runs out. The user is responsible for manually stopping cooking with the corresponding knobs.

**WARNING:** do not force the knob when winding the timer, as this could break the internal spring.

## THERMOMETER (where applicable)

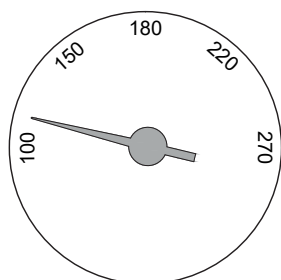

The oven is fitted with a thermometer which indicates the temperature at the centre of the oven. This allows better control of cooking and more accurate regulation.

When the oven is turned on, the burner will run at maximum power, increasing the internal temperature. When the set temperature is reached, the thermometer dial will stop and the heat will be optimally distributed inside the oven. In the event that the temperature changes significantly or such as to affect cooking, the thermometer needle will show this variation.

When the oven is switched off, the temperature will slowly go down until it reaches the ambient temperature.

N.B.: The thermometer temperature may not coincide with the one selected on the thermostat. The exact temperature is that indicated on the thermostat knob.

## ACCESSORIES / OPTIONAL EXTRAS

### TELESCOPIC RAILS

The telescopic rails can be installed on any level of the oven guides

- Locate the two spring clips (front and rear) on the telescopic rail.
- Locate the pin indicating the rear part of the rail.
- Position the telescopic rail flush with the upper edge of the selected level.
- Insert the front clip, pushing it towards the side guide.
- Insert the rear clip, pushing it towards the side guide.
- Repeat the insertion operation for the other side.
- Pull both rails out and position the oven rack or tray between the rear pin and the front stop.

### Removing the Telescopic Rails

- Locate the two spring clips (front and rear) on the telescopic rail.
- Keeping the front clip pushed down, pull the rail towards the interior of the oven.
- Repeat for the rear clip.

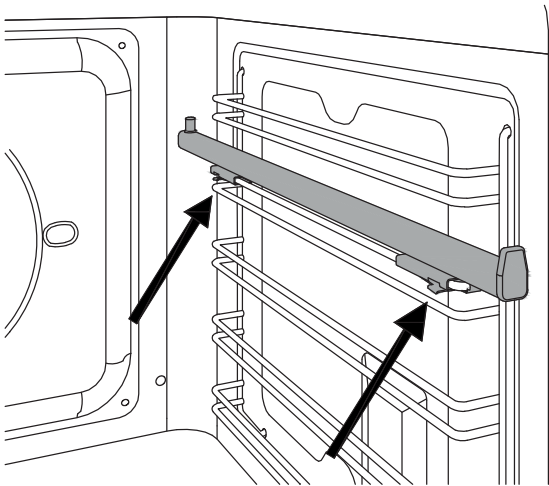
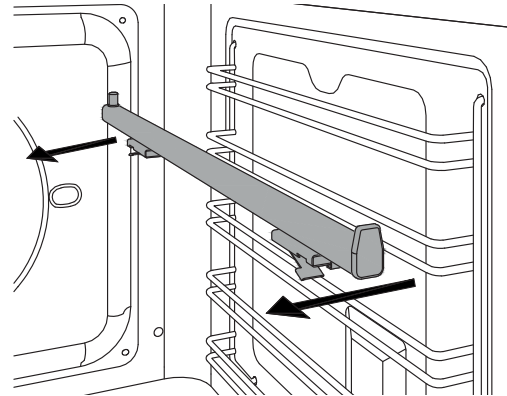

### ROTISSERIE FUNCTION

Used to cook joints of meat, chickens and fish evenly on all sides using the grill element.

- Position the skewer support in level 3 of the side guides.
- Place a tray on one of the lower levels of the side guides to collect cooking grease.
- Insert the meat or fish on the rotisserie skewer using the fork.
- Insert the skewer in the rotisserie motor housing, located in the rear of the oven, and rest it on the skewer support.
- Remove the plastic handle from the skewer.
- Select the grill function at maximum temperature.
- When cooking is complete, refit the plastic handle and remove the food from the oven.

**Important: rotisserie cooking must always be performed with the oven door closed.**

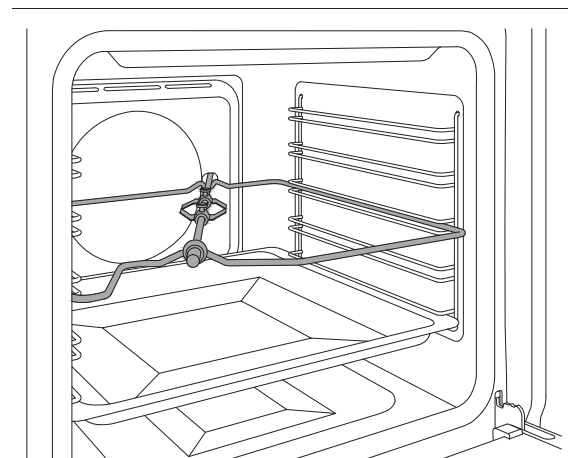
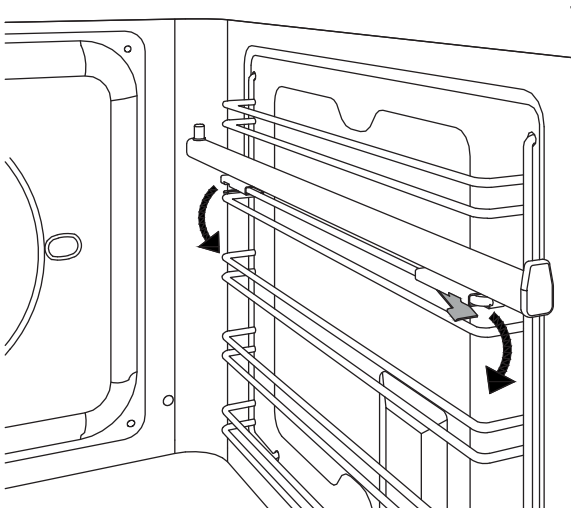

## CLEANING THE APPLIANCE

Before performing any cleaning operation, wait for all parts to cool down and isolate the oven's electricity and gas supply.

Scrupulous care of your oven will help keep it in excellent condition for many years to come.

### **Cleaning enamelled or painted parts:**

To maintain the characteristics of the enamelled components, they should be cleaned frequently with soapy water. Never use scouring powders. Do not leave acidic or basic substances (vinegar, lemon juice, salt, tomato juice etc.) sitting on enamelled parts, and do not wash enamelled parts when they are still hot.

### **Cleaning Stainless-Steel Parts:**

Clean the components with soapy water and then dry them with a soft cloth, following the direction of the brushed finish. The shine can be maintained by periodic use of commonly available products. Never use scouring powders or pads.

Immediately remove limescale, grease, starch or egg-white stains.

### **Cleaning the Door Glazing:**

To degrease, use washing-up liquid and vinegar, then rinse; otherwise, clean with washing-up liquid, rinse, then pass over with a moist cloth before drying.

To remove encrusted food, soak with soapy water or washing-up liquid for a few minutes. After a few minutes, rinse off then dry with a soft cloth.

Avoid anti-limescale, abrasive and multi-purpose products, as they will affect the look of the glass after a while.

### **Cleaning the Oven Racks:**

Do not wash the racks in the dishwasher.

Immerse them in hot soapy water, then wipe with a non-abrasive sponge before rinsing and drying with a tea towel.

**WARNING:** if they are not dried correctly, rust spots could develop.

### **Cleaning Handles:**

Clean the components with soapy water and then dry them with a soft cloth, following the direction of the brushed finish. Never use scouring powders or pads.

### **Seal:**

Wipe with a damp cloth.

### **Cleaning the burner compartment:**

To remove any food residue which has fallen through the slots on the base of the oven, remove the oven base by unscrewing the retaining screws. When you have finished cleaning, refit the oven base.

## BASIC MAINTENANCE

### REMOVING THE SIDE GUIDES

- Identify the two hooks at the bottom of the guide assembly and pull them gently downwards.
- Pull the guide assembly away from the side of the oven and remove by pulling the upper hooks of the assembly upwards from the side of the oven.
- Remove the side guide assembly from the oven.

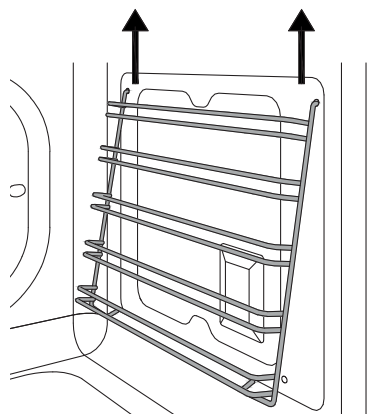
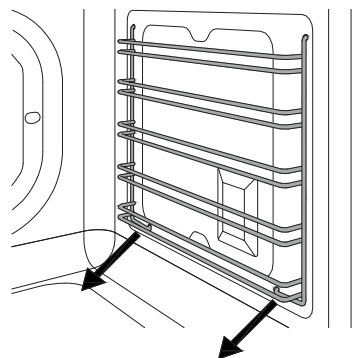

### REPLACING THE OVEN LIGHT

#### Warning!

Isolate the oven's power supply before changing the light bulb. DO NOT touch the bulb with your bare hands.

#### Upper oven light

Bulb type: G9 halogen, 220 V, 40 W

- Ensure that the oven is off and cool.
- Unscrew the glass cover and take out the old halogen bulb.
- Insert a new halogen bulb in the holder. DO NOT touch the bulb with your bare hands.
- Screw the glass cover back on.
- Reinststate the power supply.

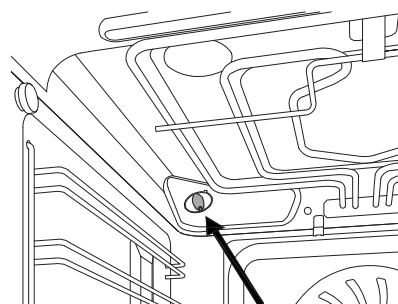
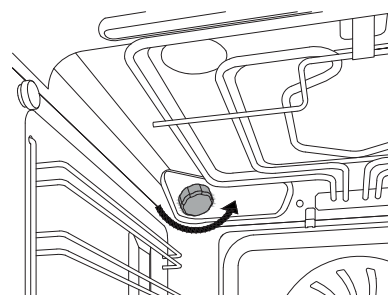



## CLEANING THE INTERNAL DOOR GLASS

The internal door glass can be easily removed for cleaning. It is not necessary to remove the door in order to clean the glass.

The glass can be cleaned in place, or removed for cleaning.

- Fully open the oven door.
- Fully open the blocking levers for both hinges.
- Slowly close the door until it blocks, checking that the levers have blocked the door.
- Remove the top cover of the door by pressing the round buttons on the left and right.
- Lift the top cover and remove.

Paying attention to the sides of the panes (do not invert or turn round):

- Slide the panes of glass out.
- Clean the glass.
- Repeat the operations above in reverse to reassemble the door.

**If the hinges are not correctly blocked and the internal glass is removed, the door can close by itself.**

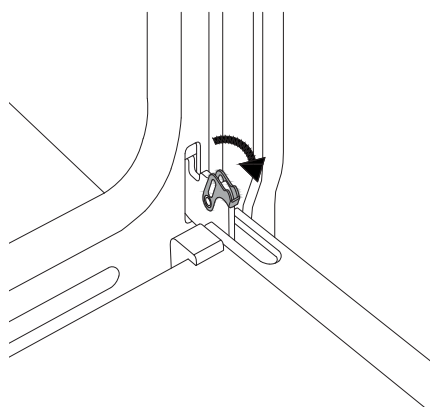
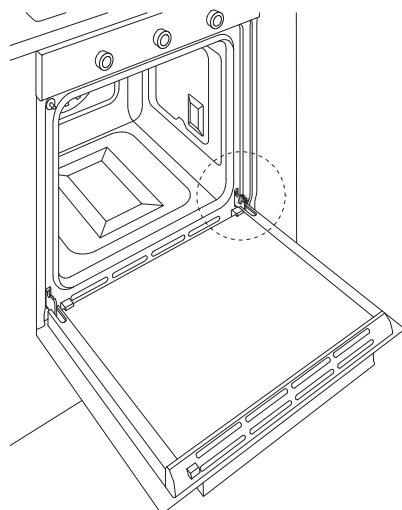
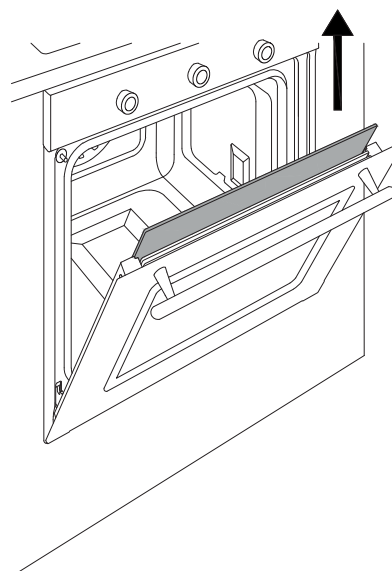
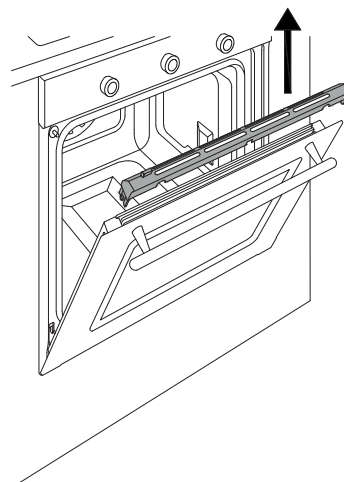
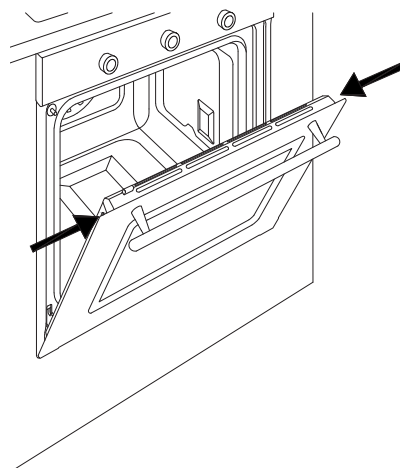
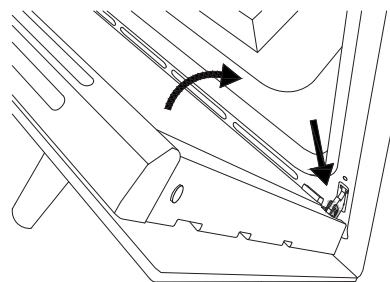

## TROUBLESHOOTING

### **The igniter does not operate**

Is the oven door open?

Is the oven power supply active? Check the circuit breaker, switch or fuse.

### **The igniter operates, but the oven does not light**

Is the gas valve open?

### **The knob will not stay in place.**

The knob clip is broken: call customer service for a replacement.

### **Food is overcooked**

When using a fan-assisted function, remember to lower the cooking temperature by 20°C

### **Food is overcooked at the bottom**

The gas oven produces a lot of heat at the bottom of the oven: place the rack or tray on a higher level

### **Food is undercooked**

When cooking large quantities of food, the cooking time must be increased proportionally.

Check that there is sufficient space around the oven dish to allow heat to circulate correctly.

Have a technician check the actual mains voltage.

### **Condensation forms on the oven door glass.**

When cooking foods with a high water content, it is normal for condensation to form on the inside of the oven door and on the control panel. This condensation will evaporate by itself during cooking. Pre-heat the oven to reduce condensation build-up.

### **Smoke forms during cooking.**

It is normal for smoke to form inside the oven when cooking particularly fatty foods. When cooking with the grill, a certain quantity of smoke is normal.

